

**OPERATING INSTRUCTIONS  
AND PARTS LIST FOR  
IVES-WAY  
AUTOMATIC  
CAN SEALER**

**Model Number**

The Model Number of your Can Sealer will be found on the lever. Always mention this number when communicating with us regarding your Can Sealer or when ordering parts.

**How to Order Parts**

When ordering repair parts, always include the following information:

1. The part number and name.
2. The model number, which will be found on the lever.

If Sealer Head is ever in need of repair, it is recommended that it be returned to the factory. Do not attempt to remove the two screws on the front, underside of the head.

This list is valuable: It will assure your being able to obtain proper part service at all times. We suggest you keep it with other valuable papers.

**IVES-WAY PRODUCTS, INC.**  
2030 NORTH NICOLE LANE  
ROUND LAKE BEACH, ILLINOIS 60073-2288  
PHONE: (847) 740-0658

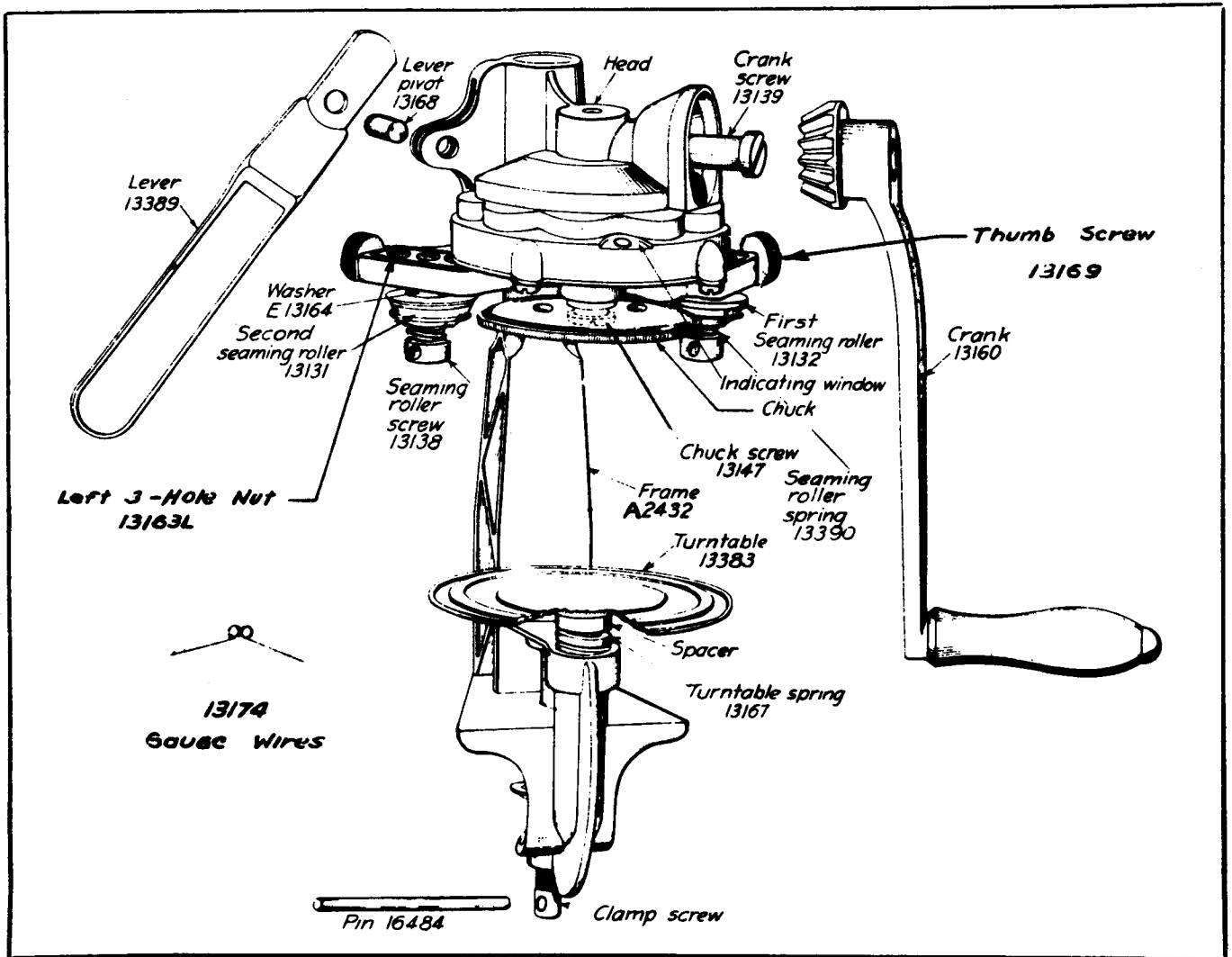

## PARTS LIST

Quantity	Part No.	Part Name
1	A2432	Frame Assembly
1	13131	Second Seaming Roller
1	13132	First Seaming Roller
2	13138	Seaming Roller Screw
1	13139	Crank Screw
1	13147	Chuck Screw
1	13160	Crank Assembly
1	13163L	Left 3-Hole Nut
1	13163R	Right 3-Hole Nut
2	E13164	Roller Washer
1	13167	Turntable Spring
1	13168	Lever Pivot
2	13169	Thumb Screw
1	13174	Gauge Wires
1	13383	Turntable
1	13389	Lever
2	13390	Seaming Roller Spring
1	16484	3" Pin
1	16485	Instruction Sheet

The part number of the spacer and chuck varies depending on the model of your sealer. See the first page of your instruction sheet for location of the model number. The table below shows the part numbers of these items for your particular sealer.

Model No.	Can Size	Spacer Part No.	Chuck Part No.
40	1	B13171	A13152
50	2	A13171	B13152
60	2-1/2	D13164	C13152
70	3	None	D13152

Other Model Numbers shown on insert page.

# Instructions for Care and Operation

Your sealer comes with the crank and lever detached. To assemble, clamp the sealer to a table using the pin to tighten the clamp screw. Do not overtighten this screw or use an extension on the end of the pin to gain more leverage. A moderate amount of force on the pin furnished is sufficient to secure the sealer to the table. The hand lever is used for raising and lowering the head and should be inserted into the slot on the left side of the head. The lever should project through the head and enter the slot in the frame post. Check the alignment of the holes in the lever and the head and insert the lever pivot from the back, with the knurled side of the pivot out. Tap the pivot in all the way, moving the lever slightly, if necessary, to align the holes. To attach the crank, turn the chuck by hand until the "O" appears in the center of the window. Insert the gear end of the crank into the housing so that it hangs down and a few inches forward. While holding the crank in this position, insert the crank screw and tighten. Before using the sealer, oil all points shown in Fig. 5.

## SEALING CANS

Before sealing, turn crank, if necessary, so that the "O" is in the center of the window. When the can is ready for sealing, hold it in your right hand and center a cover on top of the can. Raise the lever with the left hand and center the can on the turntable. Lower lever slowly and move can sideways, if necessary, to center chuck on the cover. Press lever down to locked position. Turn crank clockwise and note first and second operations taking place automatically as "1" and "2" appear in the window respectively. The crank should turn rather hard toward the end of each operation so that the seam will be rolled "tight". Continue turning until "0" reappears in window. The can is then tightly sealed. Lift lever to remove sealed can. The rollers may loosen on account of newness. On new sealers be sure to check both rollers and adjust, if necessary, during sealing of first two dozen cans. See Adjustment procedure below.

## ADJUSTING SEAMING ROLLERS

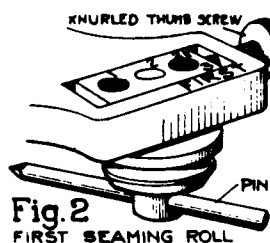
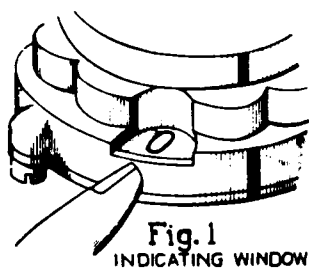

Fig. 3

CORRECT ADJUSTMENT  
OF SEAMING ROLLS  
SHOWING PROPER USE  
OF GAUGE WIRES.

The first seaming roller is on the right side of the sealer (Fig. 2) and is for curling the seam. Turn the crank until "1" appears in the window. Loosen the roller screw with the pin and loosen the thumb screw two or three turns. Slide the seaming roller assembly back until the 3-hole nut touches the thumb screw or stops against the rocker frame. Remove the pin and retighten the roller screw by hand. Insert the heavy gauge wire between the chuck and the first seaming roller (Fig. 3). Tighten the thumb screw until a drag is felt on the gauge wire as it is being pulled forward, then tighten the thumb screw an additional 1/4 turn. Lock the roller screw in place by tightening with the pin. Check to see that the gauge wire cannot be pulled out easily. If it can, loosen the roller screw slightly and tighten the thumb screw slightly. Lock the roller screw in place and re-check to see that the gauge wire cannot be pulled out easily. If it still can, repeat the above step until it cannot. To remove the gauge wire turn the crank clockwise. After the adjustment is complete and the roller screw is locked in place, tighten the thumb screw. The second seaming roller is on the left side of the sealer and is for flattening the seam. Turn the crank until "2" appears in the center of the window. The thin gauge wire is used to adjust this seaming roller (Fig. 3). Follow the same procedure used for the first seaming roller, except turn the crank counterclockwise to remove the gauge wire.

## REMOVING THE CHUCK

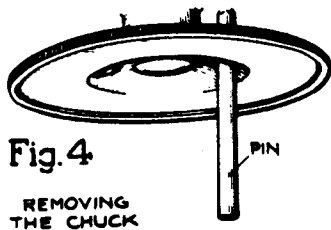

Fig. 4

REMOVING  
THE CHUCK

If replacement of the chuck becomes necessary it can be removed as shown in Fig. 4. Place the pin through one of the two holes in the chuck, to keep it from turning, and urge the crank counter-clockwise until chuck is loose. Then turn the crank until the "O" is in the window and unscrew the chuck by hand. After unscrewing hold chuck in hand and strike the threaded end of the chuck screw with the flat side of a hammer. This will pop the screw out of the chuck. To replace the chuck, insert screw in the center hole of the chuck, from the hollow side and screw into place by hand. Put the pin through one of the holes as before and urge the crank clockwise until tight.

## LUBRICATION INSTRUCTIONS

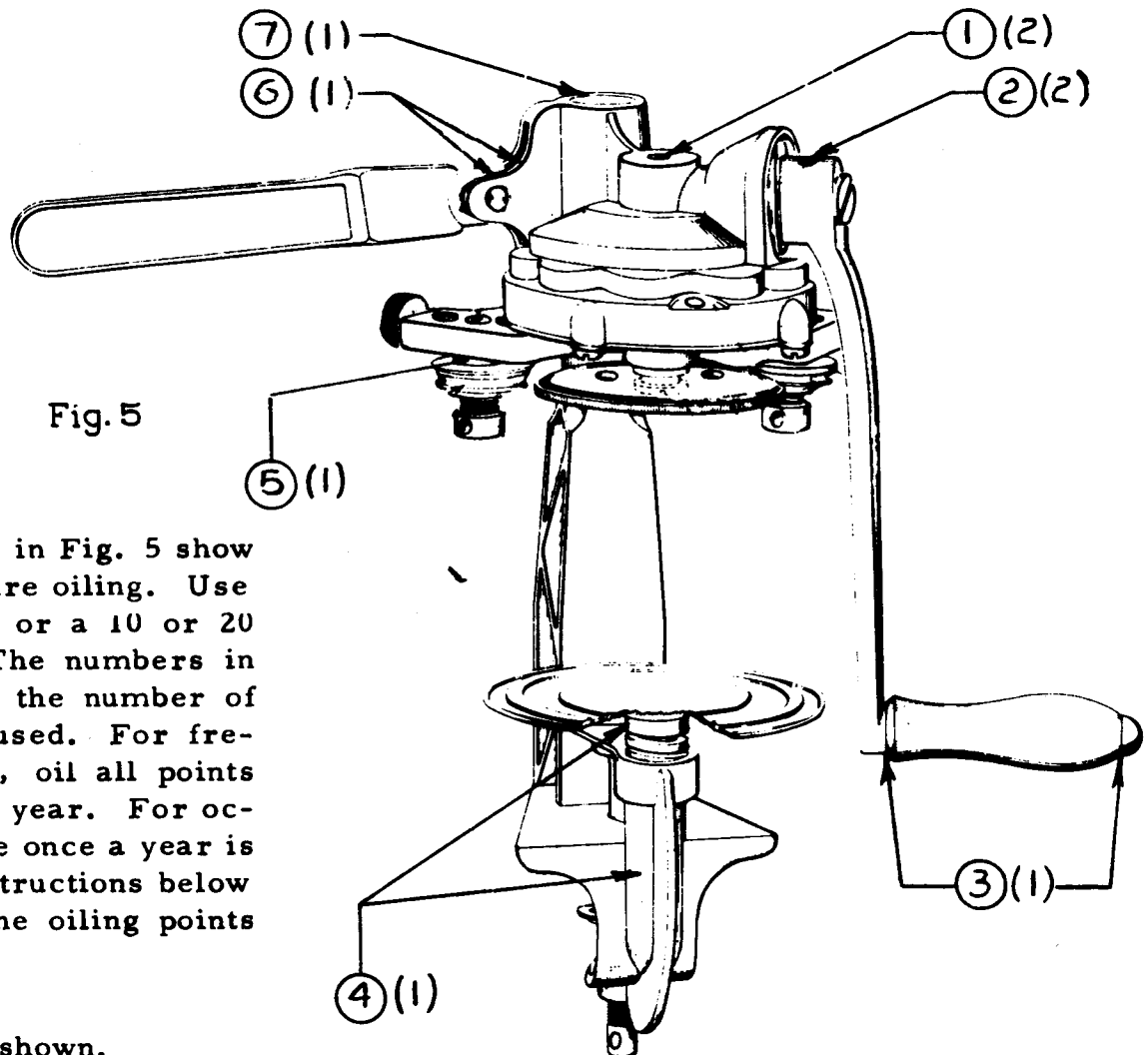
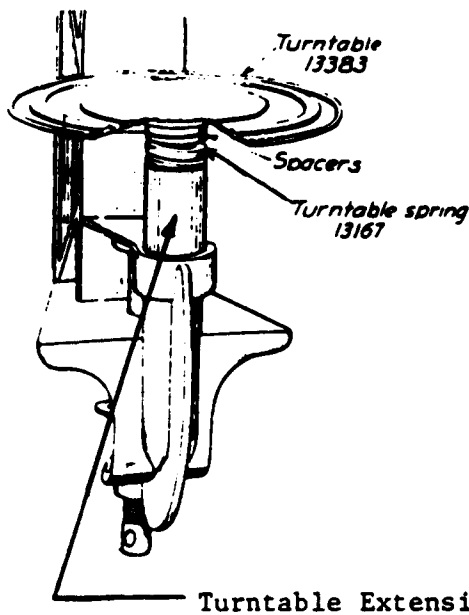

Fig. 5

The circled numbers in Fig. 5 show the points that require oiling. Use a light machine oil or a 10 or 20 weight motor oil. The numbers in parenthesis indicate the number of drops of oil to be used. For frequent or heavy use, oil all points two or three times a year. For occasional or light use once a year is sufficient. In the instructions below the numbers are the oiling points circled in Fig. 5.

- 1- Apply oil to hole shown.
- 2- Apply oil to hole shown.
- 3- Slide the handle away from the point that is being oiled. Apply oil, then rotate handle to allow oil to be drawn into the hole in the handle.
- 4- Remove the turntable and apply one drop of oil to each side of the spacers and on the turntable stem.
- 5- Apply oil to outside surface of washer. This is required on both the first and second seaming roller washers.
- 6- Move lever to "Up" position and apply oil above lever pivot and at end of lever inside the slot in the head.
- 7- With lever still in "Up" position apply oil to inside surface of head.



### INSTRUCTIONS FOR FISH CANS

The tables below show the chuck size, number of spacers and the position of the seaming roller screws for various sizes of cans. If the chuck must be replaced, first remove the existing chuck (see instruction sheet for procedure). Then reposition the seaming roller screws, but do not tighten yet. Loosen the thumb screws and slide the 3-hole nuts out as far as they will go. Tighten the seaming roller screws by hand only, then install the correct size chuck. Adjust seaming rollers as shown in your instruction sheet.

### INSTRUCTIONS FOR FLAT FISH CANS

For these cans the turntable extension shown above is used between the frame and turntable. Use following table to determine the number of spacers, chuck size and seaming roller location:

CAN SIZE DIAMETER X HEIGHT	CAN INDUSTRY SIZE	NUMBER AND SIZE OF SPACERS	CHUCK SIZE	POSITION OF SEAMING ROLLER SCREWS IN 3-HOLE NUTS
3 7/16 x 2	307x200	2-3/16" 1-5/16"	#2 307	
4 1/16 x 2 5/16	401x205	2-3/16"	#2 1/2	#2 1/2 Hole
4 1/16 x 2 11/16	401x211	None	401	
4 1/4 x 2 3/8	404x206	1-5/16"	#3 404	#3 Hole

### INSTRUCTIONS FOR TALL SALMON CANS

The turntable extension is NOT required for this can. Use the following table to determine the number of spacers, chuck size and seaming roller location:

CAN SIZE DIAMETER X HEIGHT	CAN INDUSTRY SIZE	NUMBER AND SIZE OF SPACERS	CHUCK SIZE	POSITION OF SEAMING ROLLER SCREWS IN 3-HOLE NUTS
3 1/16 x 4 8/16	301x408	2-3/16"	#301	#2 Hole

### ADJUSTING FOR VARIOUS CAN SIZES

When setting up your sealer for the can size that you want to seal:

1. Unscrew the seaming roller screws with the pin and screw them finger tight into the proper hole in the 3-hole nuts (Fig. #2 and Table I below). Loosen the thumb screws and slide the 3-hole nuts out as far as they will go in the slotted frame in which they are mounted.
2. Install the correct chuck on the sealer head (Fig. #4) and use the proper spacer or spacers under the turntable as shown in Table I.

**TABLE I**

	#1 Cans (211x400)	#2 Cans (307x409)	#2½ Cans (401x411)	#3 Cans (404x414)	#300 Cans (300x407)	#303 Cans (303x406)
Chuck Size	211	307	401	404	300	303
Spacers Required	1-Thick	1-Medium	1-Thin	None	1-Medium 1- 1/8"	1-Medium 1-Thin
Position of Seaming Roller Screws in 3-Hole Nuts	#1 Hole	#2 Hole	#2½-3 Hole	#2½-3 Hole	#2 Hole	#2 Hole

#### S P A C E R   H E I G H T

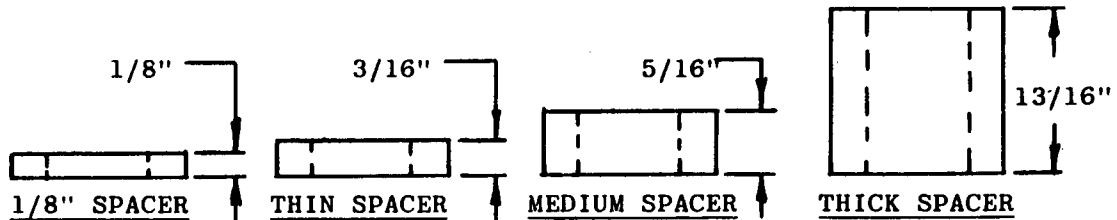

3. Adjust the seaming rollers (Fig. #1, 2 and 3).
4. Before sealing cans, make sure that the correct size and number of spacers are used for the can size being sealed (See Table I above).

#### LEAK TESTING

Before canning, seal several empty cans until you learn how the sealer works. These empty cans should then be checked for leakage by placing them in a pan of water that has been brought to a boil and then removed from the stove. The water should be deep enough to cover about 1/2 of the can when the cans are standing upright. Insert the cans upside down (newly-sealed end down) in the hot water. Hold each can down with a larger-size filled can from your pantry or with a pot holder. The heat will expand the air in the can and within a few seconds a stream of bubbles will be seen coming from a leaky seam. Small bubbles clinging to the seam do not indicate leakage. The ends of the cans might "pop" when the can is put into the hot water, but this is normal and should cause no concern. If a leaky seam is detected, readjust the seaming rollers and repeat the leakage test. Canning should not proceed until the seaming rollers have been adjusted properly and the seams do not produce a stream of bubbles in the leakage test. The rollers may loosen because of newness, so on new sealers, repeat the leakage test after sealing the first dozen cans.

#### CHUCKS AND SPACERS

In addition to the parts shown in the parts list, the table below shows the number of chucks and spacers included with the model number shown.

Model No.	#211 Chuck Part # A13152	#307 Chuck Part # B13152	#401 Chuck Part # C13152	#404 Chuck Part # D13152	#301 Chuck Part # S13152	#303 Chuck Part # E13152	Thin Spacer Part # D13164	Medium Spacer Part # A13171	Thick Spacer Part # B13171	Turntable Extension Part # 18102
100					1		2			
200	1	1	1	1			1	1	1	
300		1		1				1		
400		1	1		1		2	1		1
500	1	1	1	1	1		2	1	1	1
600		1		1			2	1		1
700		1	1				1	1		
800		1			1		2	1		1
900*		1			1		2	2	1	1

\* ASSEMBLED WITH CHUCKS, SPACERS, AND EXTENSIONS AS REQUESTED BY THE CUSTOMER

**TURNTABLE HEIGHT ADJUSTMENT**  
**IVES-WAY MODEL 900**

a)	301 x 408	(16oz/1lb tapered)	2 thin spacer	3/16"
b)	307 x 200.25	(8oz/1/2lb tapered)	Extension post 1 medium spacer 5/16" 2 thin spacer 3/16"	Extension post <b>OR</b> 3 thin 3/16" 1 extra thin 1/8"
c)	307 x 306	(13oz)	2 medium spacer 1 thick spacer	5/16" 13/16"
d)	307 x 409	(19oz)	1 medium spacer	5/16"
e)	401 x 411	(28oz)	1 thin spacer	3/16"

**Wells Can Company Ltd.**  
**8705 Government Street**  
**Burnaby, BC V3N 4G9**  
**(604)420-0959 Fax(604)420-0975**  
**e-mail [sales@wellscan.ca](mailto:sales@wellscan.ca)**  
**website [www.wellscan.ca](http://www.wellscan.ca)**